

TURBOJET 325

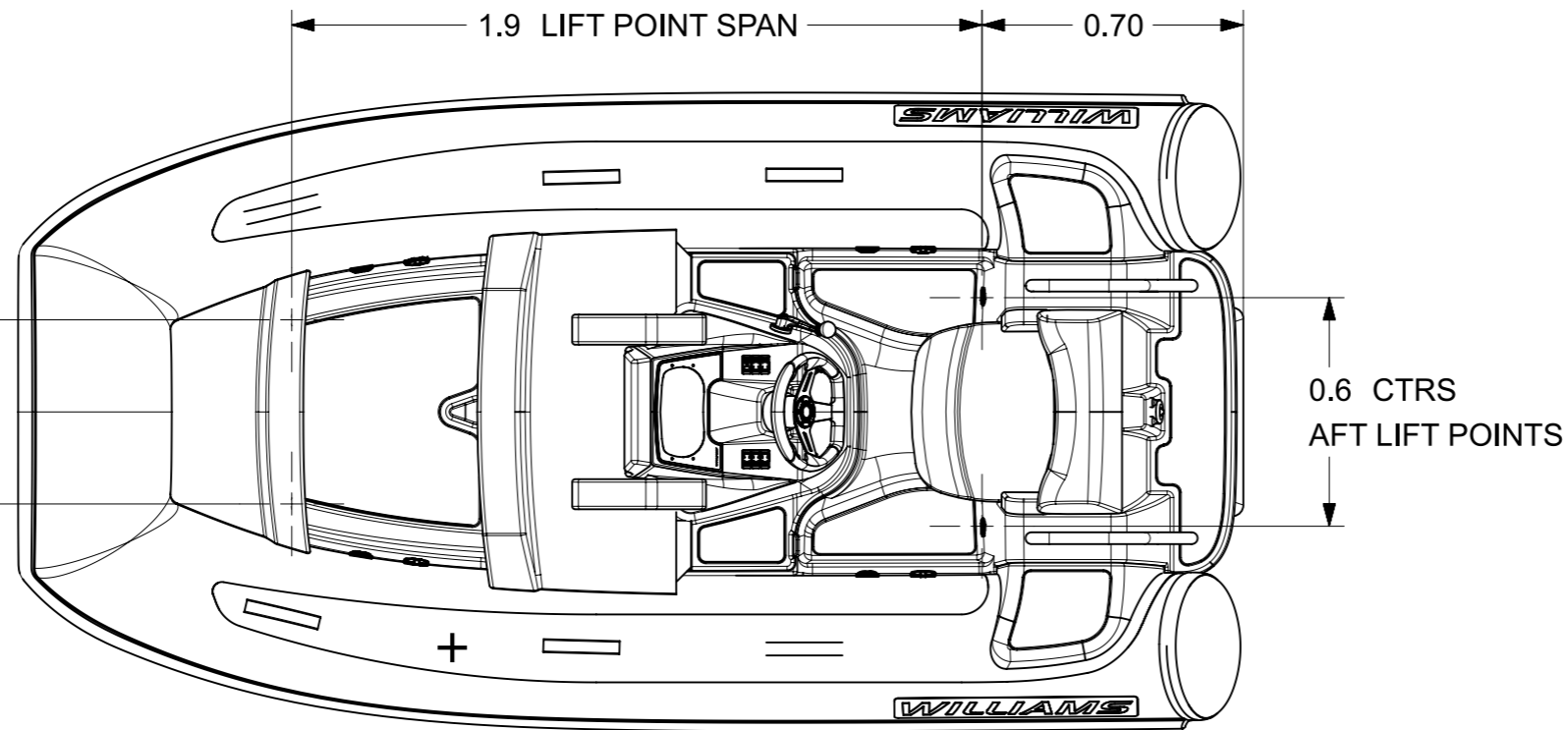

LENGTH O.A.	3.29m (±1.%)
BEAM O.A.	1.70m (±1.5%)
DRAFT (FULLY LOADED)	0.23m / 0.35m
ENGINE	Rotax ACE 90 ECT
POWER	90hp ≅ 66.19kW
DRY WEIGHT	325kg
SEATING CAPACITY	4 + 1 child
FUEL	PETROL
FUEL CAPACITY	40L
MAX. SPEED	48mph ≅ 77kph
No. TUBE COMPARTMENTS	4
CE DESIGN CATEGORY	C

NOTES:

1. LENGTH/ BEAM TOLERANCE DUE TO VARIATION IN TUBE AIR PRESSURE.
2. AVERAGE DRY WEIGHT STATED; ACTUAL WEIGHT DEPENDANT ON OPTIONS FITTED.
3. LOW PROFILE SPEC:
 - REMOVE STEERING WHEEL (QUICK RELEASE TYPE REQUIRED*)
 - DEFLATE TUBES.
 - REMOVE BACKREST.
4. STANDARD CHOCKS*: 99-0152
CHOCK PROFILES DRAWING: RD1014

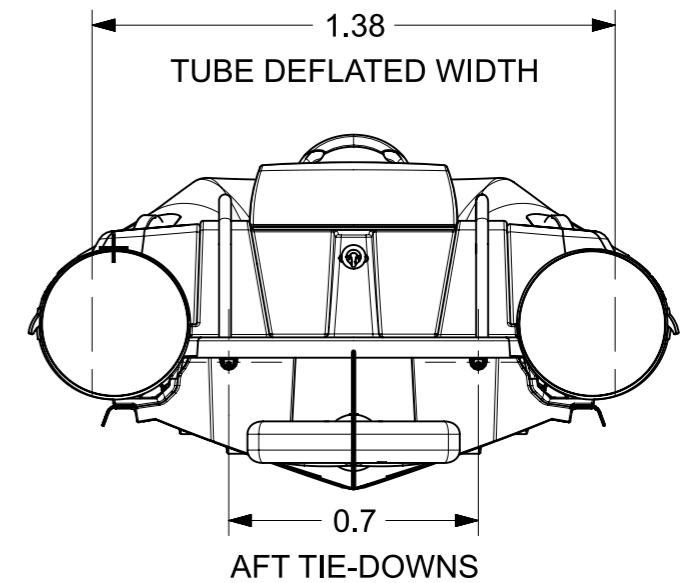
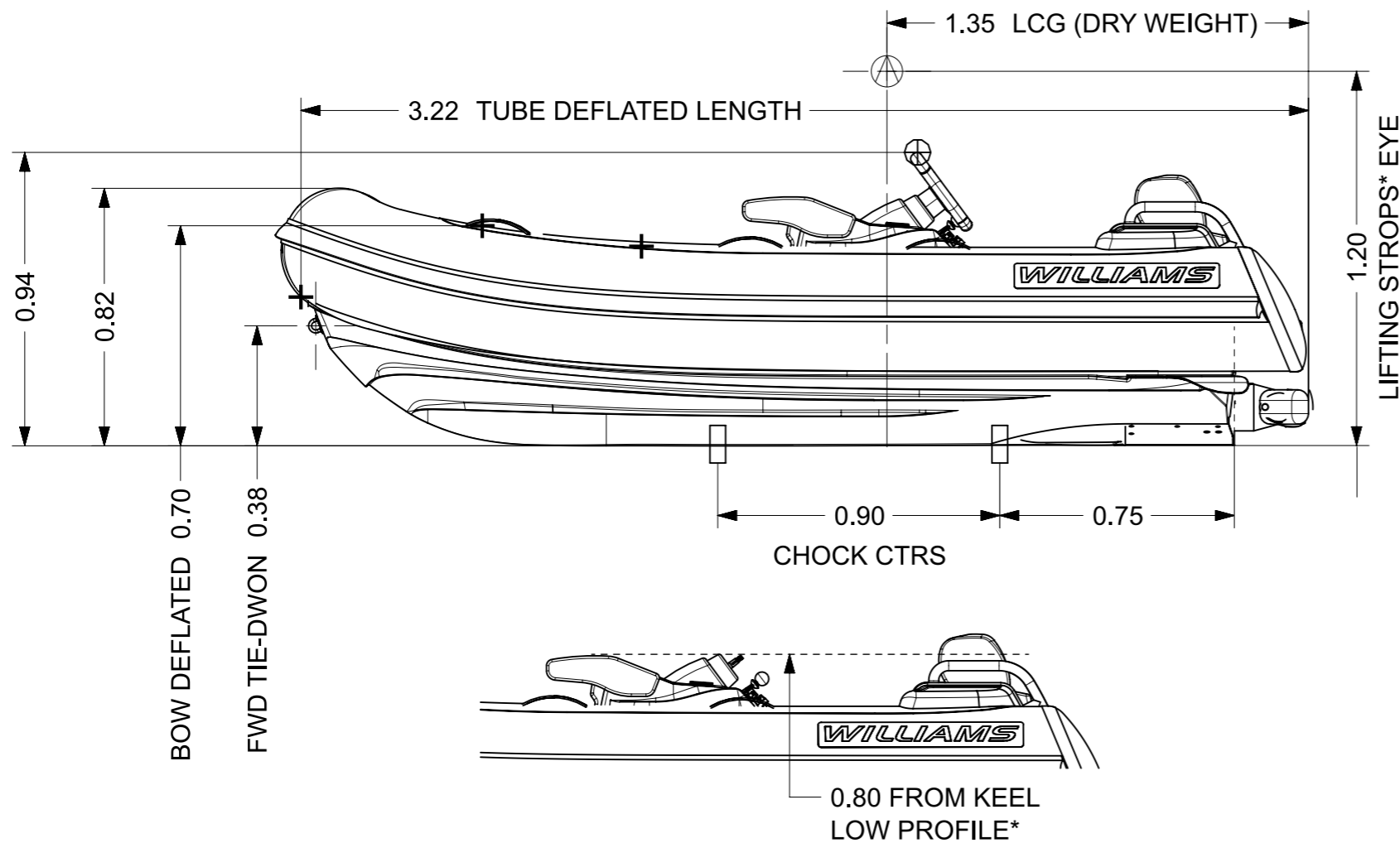

REV.	DATE	DETAILS	FZ	OB
1	10/10/2023	DOCUMENT PRODUCTION	FZ	OB
			DRAWN	APPV'D

GENERAL TOL.
 0 ±0.50
 0.0 ±0.25
 0.00 ±0.10
 0° ±0.50°

NOT FOR PUBLICATION - THIS DRAWING IS THE PROPERTY OF WILLIAMS JET TENDERS LTD. AND IS ISSUED ON CONDITION THAT IT IS NOT COPIED, RE-PRINTED OR DISCLOSED EITHER WHOLLY OR IN PART TO ANY THIRD PARTY NOT AUTHORISED TO RECEIVE IT

NAME	DATE
DRAWN FZ	12/10/2023
APPV'D OBB	
PROJECT:	-
INSPECTION LEVEL:	-
MATERIAL & FINISH	-
	-

WILLIAMS

TITLE
TURBOJET 325 (2025MY)

PART NO.
WPT-000325TJ2025MY-DATASHEET-dwg

SCALE 1:20

SHEET 1 OF 1

A3