

SPORTJET 345

LENGTH O.A.	3.45m (±1%)
BEAM O.A.	1.77m (±1.5%)
DRAFT (FULLY LOADED)	0.33m
ENGINE	Rotax ACE 90 ECT
POWER	90hp ≅ 66.19kW
DRY WEIGHT	362Kg
SEATING CAPACITY	5
FUEL	PETROL
FUEL CAPACITY	50L
MAX. SPEED	46mph ≅ 74kph
No. TUBE COMPARTMENTS	5
CE DESIGN CATEGORY	C

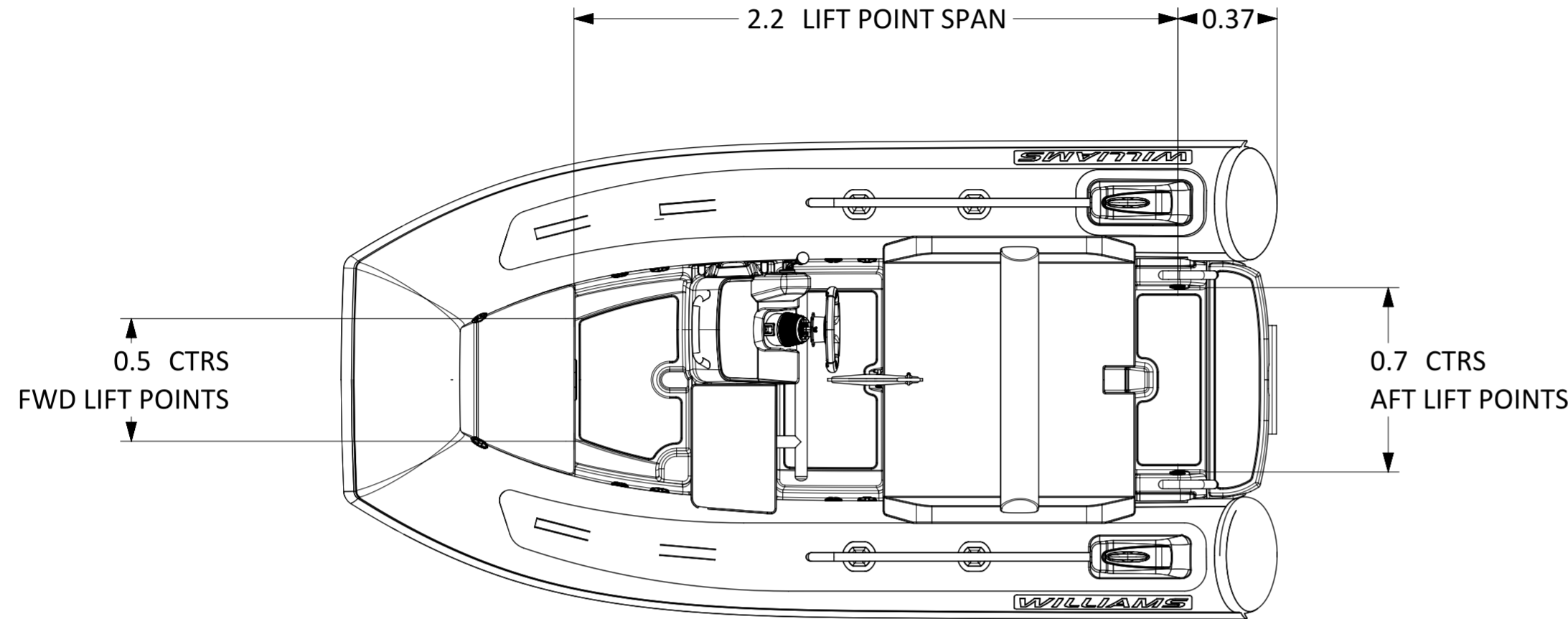

NOTES:

1. LENGTH / BEAM TOLERANCE DUE TO VARIATION IN TUBE PRESSURE.
2. AVERAGE DRY WEIGHT STATED; ACTUAL WEIGHT DEPENDENT ON OPTIONS FITTED.
3. LOW PROFILE SPEC:
-DEFLATE TUBES (AUTOMATIC BOW TUBE INFLATOR OPTION REQUIRED).
-REMOVE STEERING WHEEL (QUICK RELEASE WHEEL OPTION REQUIRED).
4. STANDARD CHOCKS*: 99-0152
CHOCK PROFILES DRAWING: RD1014

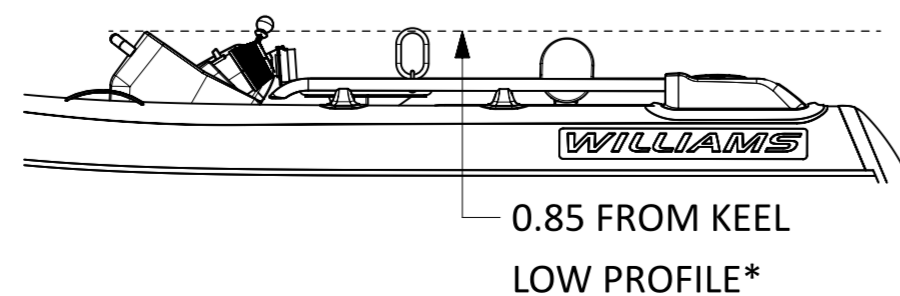
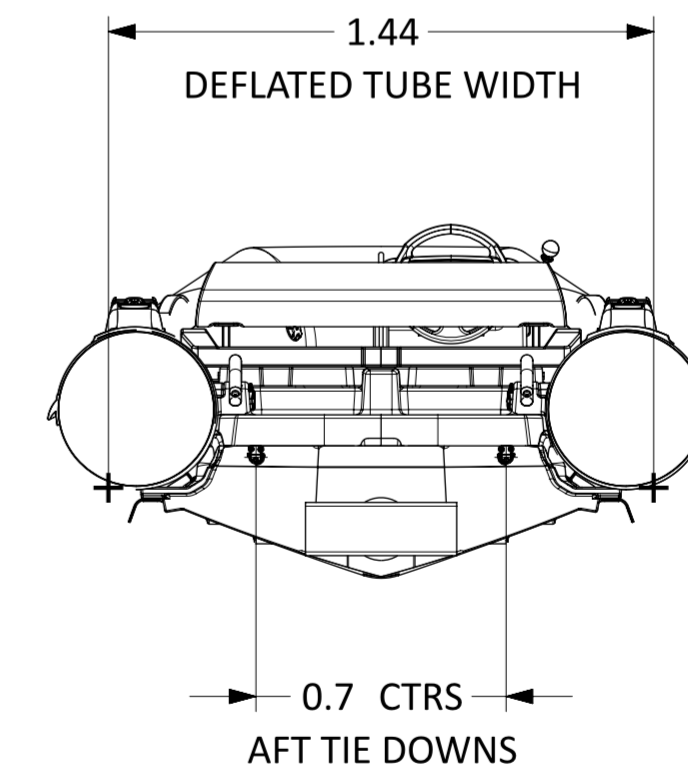
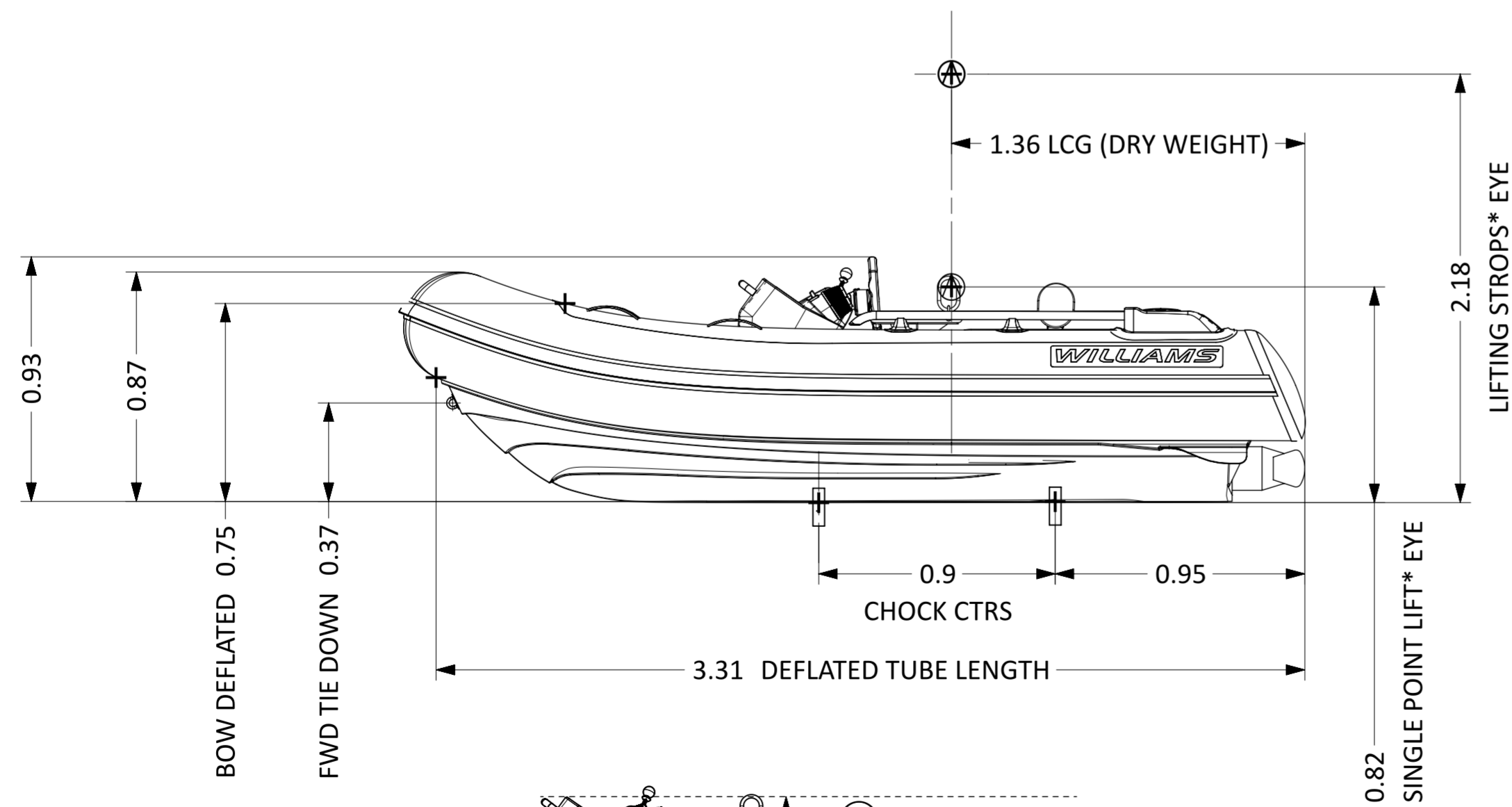

* OPTIONAL ACCESSORY

REV.	DATE	DETAILS	FZ	OBB
1	18/09/2023	PRODUCTION RELEASED	FZ	OBB

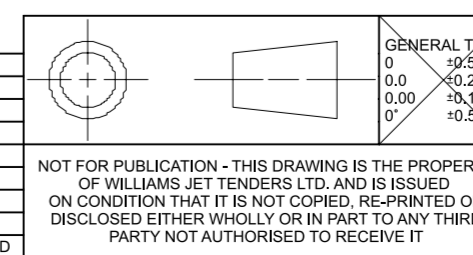

GENERAL TOL.	0 ±0.50
	0.0 ±0.25
	0.00 ±0.10
	0 ±0.30

DRAWN	FZ	DATE	18/09/2023
APPVD	OBB		
PROJECT:			
INSPECTION LEVEL:			
MATERIAL & FINISH			

WILLIAMS

TITLE: **SPORTJET 345 (2024MY)**

PART NO.: **WPT-000345SJ-2024MY-DATASHEET -dwg.1**

SCALE: 1:20

SHEET 1 OF 1

A2